



FLOTECT® MODEL V6 FLOW SWITCH

Installation and Operating Instructions

**Explosion-Proof; U.L. and C.S.A. Listed –
Class I, Groups *A, B, C & D
Class II, Groups E, F & G
CENELEC: EExd IIC T6 (T amb=75°C)
*(Group A, stainless steel body only)**

PHYSICAL DATA

Maximum Temperature: 220°F (105°C); 400°F (205°C) with high temperature (MT) option – Not U.L., C.S.A. or CENELEC approved.

Maximum Pressure: See chart.

Electrical Ratings: U.L. – 5A @ 125/250 VAC. C.S.A. and CENELEC – 5A @ 125/250 VAC, 5A resistive, 3A inductive @ 30 VDC. Gold contacts (MV option) for dry circuits – 0.1A @ 125 VAC. High temperature (MT) option – 5A @ 125/250 VAC. Not U.L., C.S.A. or CENELEC approved.

Wiring: U.L., C.S.A. models – 18 AWG × 18" (46 cm) length. CENELEC models – terminal block.

Switch Body: Lower housing (wetted), brass or stainless steel. Upper housing, brass or stainless steel.

Vane: Stainless steel.

Pipe Connection: 1/2" – 2" NPT tee standard. 1/2" NPT for Low Flow models and models with field trimmable vane.

Installation: Install in any position with index arrow pointing in direction of flow.

Weight: 2 – 6 lbs. (.9 – 2.7 kg) depending on size and construction.

Options: DPDT relays, custom calibration, Teflon coated wetted parts and more.

MAXIMUM PRESSURE CHART

MODEL	LOWER HOUSING	TEE	MAXIMUM PRESSURE PSI (KG/CM ²)
V6 Low Flow	Brass	Brass	1450 (102)
V6 Low Flow	Stainless Steel	Stainless Steel	1450 (102)
V6	Brass	Brass	250 (17)
V6	Brass	Iron	1000 (70)
V6	Stainless Steel	Iron	1000 (70)
V6	Stainless Steel	Forged Steel	2000 (140)
V6	Stainless Steel	Stainless Steel	2000 (140)



The Flotect® Model V6 is an inexpensive, explosion-proof flow switch for use on air, water or other compatible gases and liquids. Three configurations are available – 1. Factory installed in a tee. 2. With a trimmable vane for field adjustment and installation in a suitable tee. 3. Low flow models with an integral tee and adjustable valve. All are available with an optional enclosure which is U.L. and C.S.A. listed, CENELEC approved.

INSTALLATION

Unpack and remove any packing material found inside lower housing or tee.

Switch can be installed in any position but the actuation/deactuation flow rates in the charts are based on horizontal pipe runs and are nominal values. For more precise settings, units can be factory calibrated to specific flow rates.

V6 Models with Tee are supplied in 1/2" – 2" NPT sizes. Install in piping with arrow pointing in direction of flow.

V6 Low Flow Models have 1/2" NPT connections and are field adjustable. Install in piping with arrow pointing in direction of flow. To adjust, loosen the four socket head cap screws on bottom. The adjustment valve rotates 90° between "O" (open) and "C" (closed). See flow charts for approximate ranges. Tighten screws once the required flow rate has been set.

V6 with Field Trimmable Vane. These models enable the installer to choose approximate actuation/deactuation points by trimming the full size vane at appropriate letter-designated marks on a removable template. Flows are defined in the following charts. Note that the charts are based on either brass or cast iron reducing tees or stainless or forged steel straight tees with bushings where necessary. Install in piping with arrow pointing in direction of flow.

When bushings are used, they must be back drilled to allow proper clearance for unrestricted vane travel. Bore the I.D. to 13/16" (20 mm) on 1/2" × 3/4" bushings or 1" (25 mm) on larger bushings. The depth of the bore must leave internal threads 9/16" (14 mm) high for proper engagement between the lower housing of the switch and the bushing. Check for proper vane travel and switch operation after installation.

ELECTRICAL CONNECTIONS:

Connect wire leads in accordance with local electrical codes and switch action required. N.O. contacts will close and N.C. contacts will open when flow increases to the actuation point. They will return to "normal" condition when flow decreases to the deactuation point. Black = Common, Blue = Normally Open and Red = Normally Closed.

For units supplied with both internal and external grounds, the ground screw inside the housing must be used to ground the control. The external ground screw is for supplementary bonding when allowed or required by local code. Some C.S.A. listed models are furnished with a separate green ground wire. Such units must be equipped with a junction box, not supplied but available on special order.

CENELEC certified models include a junction box. Cable should enter enclosure through an approved EX cable gland, not supplied. Push stripped and tinned leads into appropriate openings in terminal block(s). To connect fine stranded leads or to remove any wire, depress spring release with small screwdriver first.

All wiring, conduit and enclosures must meet applicable codes for hazardous areas. Conduits and enclosures must be properly sealed. For outdoor or other locations where temperatures vary widely, precautions should be taken to prevent condensation inside switch or enclosure. Electrical components must be kept dry at all times. **CAUTION:** To prevent ignition of hazardous atmospheres, disconnect the device from the supply circuit before opening. Keep assembly tightly closed when in use.

V6 With Tee

Cold Water – Factory Installed Tee

Approximate actuation/deactuation flow rates
GPM upper, **M³/HR** lower

1/2" NPT		3/4" NPT		1" NPT		1 1/4" NPT		1 1/2" NPT		2" NPT	
1.5	1.0	2.0	1.25	3.0	1.75	4.0	3.0	6.0	5.0	10.0	8.5
0.34	0.23	0.45	0.28	0.68	0.40	0.91	0.68	1.36	1.14	2.27	1.93

Air-Factory Installed Tee

Approximate actuation/deactuation flow rates
SCFM upper, **NM³/M** lower

1/2" NPT		3/4" NPT		1" NPT		1 1/4" NPT		1 1/2" NPT		2" NPT	
6.5	5.0	10.0	8.0	14	12	21	18	33	30	43	36
.18	.14	.28	.23	.40	.34	.59	.51	.93	.85	1.19	1.02

V6 Low Flow, Field Adjustable

Cold Water – Low Flow Models

Approximate actuation/deactuation flow rates
GPM upper, **M³/HR** lower

MINIMUM		MAXIMUM	
.04	.03	.75	0.60
.009	.007	0.17	0.14

Air – Low Flow Models

Approximate actuation/deactuation flow rates
SCFM upper, **NM³/M** lower

MINIMUM		MAXIMUM	
.18	.15	2.70	2.0
.005	.004	.08	.06

V6 With Field Trimmable Vane

Cold Water – Brass or Cast Iron Reducing Tee

Approximate actuation/deactuation flow rates

GPM upper, M³/HR lower

Vane	1/2" NPT	3/4" NPT	1" NPT	1 1/4" NPT	1 1/2" NPT	2" NPT	1/2" NPT	3/4" NPT	1" NPT	1 1/4" NPT	1 1/2" NPT	2" NPT
Full Size						9.0 8.5 2.0 1.9						39.0 37.0 1.10 1.05
A						9.5 9.0 2.2 2.0						40.0 38.0 1.13 1.08
B						10.0 9.3 2.3 2.1						42.0 40.0 1.19 1.13
C						11.0 10.0 2.5 2.3						50.0 44.0 1.42 1.25
D					6.2 5.5 1.4 1.2	12.0 10.0 2.7 2.3					27.0 25.0 0.76 0.71	55.0 46.0 1.56 1.30
E					7.0 6.5 1.6 1.5	13.0 11.0 3.0 2.5					30.0 28.0 0.85 0.79	
F				4.3 3.9 1.0 0.9	7.6 7.1 1.7 1.6	14.0 12.0 3.2 2.7				20.0 18.0 0.57 0.51	32.0 30.0 0.91 0.85	
G				4.9 4.4 1.1 1.0	8.0 7.3 1.8 1.7					21.0 19.0 0.59 0.54	34.0 32.0 0.96 0.91	
H				5.5 5.0 1.2 1.1	9.0 8.2 2.0 1.9					23.0 21.0 0.65 0.59	37.0 34.0 1.05 0.96	
I		3.5 3.1 0.8 0.7	6.0 5.6 1.4 1.3	10.0 9.0 2.3 2.0				16.0 15.0 0.45 0.42	24.0 22.0 0.68 0.62	39.0 36.0 1.10 1.02		
J		4.0 3.5 0.9 0.8	7.0 6.6 1.6 1.5	13.0 11.0 3.0 2.5				18.0 16.0 0.51 0.45	28.0 25.0 0.79 0.71	51.0 45.0 1.44 1.27		
K		4.6 4.2 1.04 0.95	8.0 7.6 1.8 1.7	15.0 13.0 3.4 3.0				19.0 17.0 0.54 0.48	33.0 30.0 0.93 0.85	69.0 57.0 1.95 1.61		
L		2.6 2.3 0.6 0.5	5.6 5.2 1.3 1.2	10.0 9.0 2.3 2.0				13.0 12.0 0.37 0.34	22.0 20.0 0.62 0.57	38.0 35.0 1.08 0.99		
M	1.6 1.3 0.4 0.3	3.5 3.1 0.8 0.7	6.3 6.1 1.43 1.39	12.0 10.0 2.7 2.3			6.4 3.8 0.18 0.11	15.0 14.0 0.42 0.40	25.0 23.0 0.71 0.65	45.0 42.0 1.27 1.19		
N	2.2 1.8 0.5 0.4	4.3 3.8 1.0 0.9	8.0 7.5 1.8 1.7				10.0 7.0 0.28 0.20	20.0 16.0 0.57 0.45	32.0 28.0 0.91 0.79			
O	3.0 2.4 0.7 0.5						12.0 9.0 0.34 0.25					

Air – Brass or Cast Iron Reducing Tee

Approximate actuation/deactuation flow rates

SCFM upper, NM³/M lower

Cold Water – Stainless or Forged Steel Straight Tee and Bushing

Approximate actuation/deactuation flow rates

GPM upper, M³/HR lower

Vane	1/2" NPT	3/4" NPT	1" NPT	1 1/4" NPT	1 1/2" NPT	2" NPT	1/2" NPT	3/4" NPT	1" NPT	1 1/4" NPT	1 1/2" NPT	2" NPT
Full Size				5.0 4.5 1.1 1.0	8.5 7.8 1.9 1.8					21.0 18.0 0.59 0.51	33.0 30.0 0.93 0.85	
A				5.5 5.0 1.2 1.1	9.2 8.6 2.1 2.0					22.0 20.0 0.62 0.57	39.0 36.0 1.10 1.02	
B				6.2 5.7 1.4 1.3	9.8 9.0 2.2 2.0					24.0 22.0 0.68 0.62	42.0 38.0 1.19 1.08	
C				6.8 6.3 1.5 1.4	12.0 10.0 2.7 2.3					28.0 26.0 0.79 0.74	51.0 46.0 1.44 1.30	
D			2.8 2.4 0.6 0.5	8.5 7.8 1.9 1.8	13.0 11.0 3.0 2.5				12.0 10.0 0.34 0.28	33.0 30.0 0.93 0.85	55.0 50.0 1.56 1.42	
E			3.4 3.0 0.8 0.7	10.0 9.2 2.3 2.1					14.0 12.0 0.40 0.34	37.0 34.0 1.05 0.96		
F			4.0 3.6 0.91 0.82	12.0 10.0 2.7 2.3					16.0 14.0 0.45 0.40	43.0 40.0 1.22 1.13		
G		2.0 1.5 0.5 0.3	5.0 4.5 1.1 1.0					8.0 6.5 0.23 0.18	19.0 17.0 0.54 0.48			
H		2.5 2.0 0.6 0.5	6.5 6.1 1.48 1.39					11.0 10.0 0.31 0.28	26.0 24.0 0.74 0.68			
I		3.5 3.0 0.8 0.7	9.0 8.2 2.0 1.9					14.0 13.0 0.40 0.37	32.0 30.0 0.91 0.85			
J		7.0 5.5 1.6 1.2						27.0 24.0 0.76 0.68				
K		10.0 8.0 2.3 1.8						39.0 36.0 1.10 1.02				

Air – Stainless or Forged Steel Straight Tee and Bushing

Approximate actuation/deactuation flow rates

SCFM upper, NM³/M lower

DIMENSIONS

FloTect® Model V6

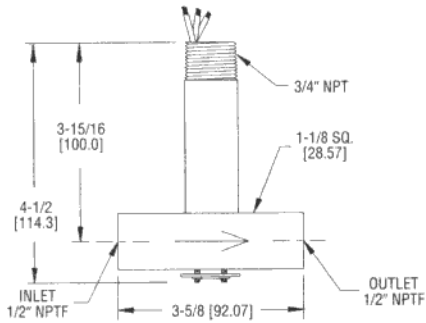

V6 Low Flow

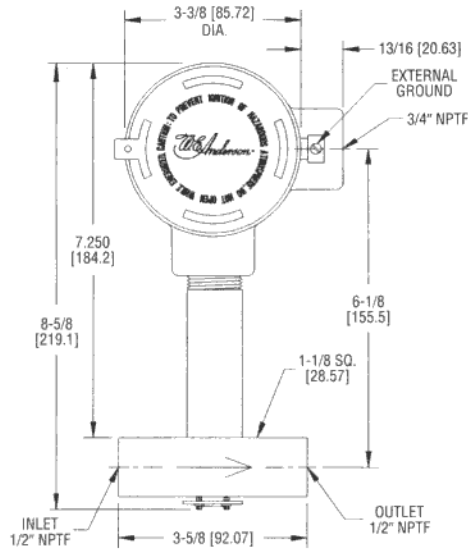

**V6 Low Flow with C.S.A.,
CENELEC Conduit Enclosure**

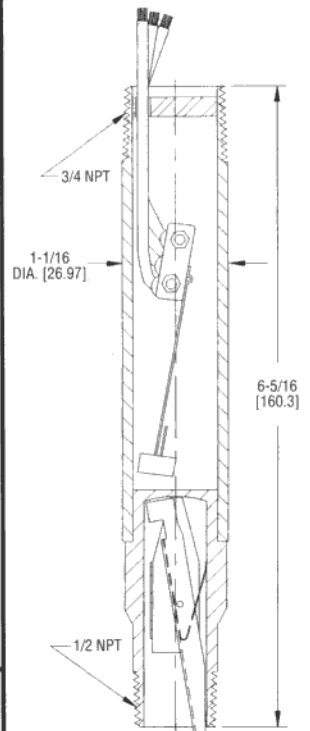

**V6 with Field
Trimnable Vane**

PIPE SIZE	BRASS/DUCTILE IRON		FORGED/STAINLESS STEEL		MALLEABLE IRON	
	DIM. A	DIM. B	DIM. A	DIM. B	DIM. A	DIM. B
1/2"	2-1/4(57)	1-1/8(29)	2-1/4(57)	1-1/8(29)	2-1/2(64)	1-1/4(32)
3/4"	2-3/8(60)	1-1/4(32)	2-5/8(67)	1-7/8(47)	2-5/8(67)	1-3/8(35)
1"	2-1/2(64)	1-3/8(35)	3(76)	2-1/8(54)	2-7/8(73)	1-1/2(38)
1-1/4"	2-5/8(67)	1-1/2(38)	3-1/2(89)	2-1/2(64)	3(76)	1-3/4(44)
1-1/2"	2-7/8(73)	1-5/8(41)	4(102)	2-3/4(70)	3-1/4(83)	1-7/8(48)
2"	3(76)	1-7/8(48)	4-3/4(121)	3-1/8(79)	3-1/2(89)	2-1/8(54)

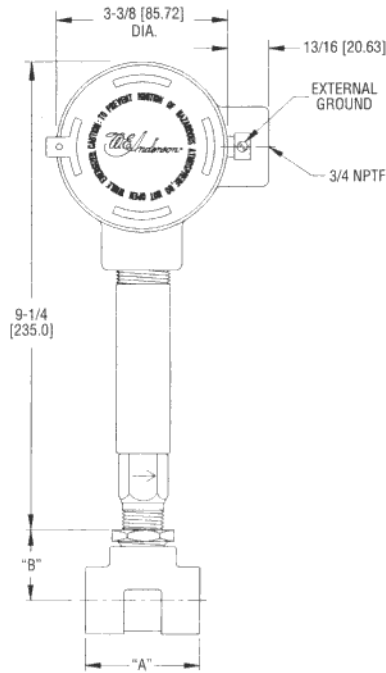

**V6 with Tee and C.S.A.,
CENELEC Conduit Enclosure**

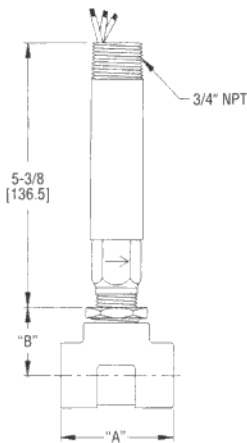

V6 with Tee

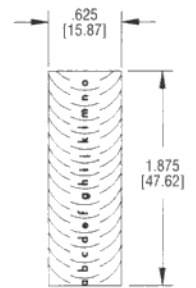

Trimnable Vane



W.E. ANDERSON DIV., DWYER INSTRUMENTS, INC.
P.O. Box 358
Michigan City, IN 46360
Phone: 219/879-8000
Fax: 219/872-9057

FR 82-440805-00
Printed in U.S.A. 1/94
©Copyright 1994 Dwyer Instruments, Inc.